

This article was downloaded by:

On: 27 January 2011

Access details: *Access Details: Free Access*

Publisher *Taylor & Francis*

Informa Ltd Registered in England and Wales Registered Number: 1072954 Registered office: Mortimer House, 37-41 Mortimer Street, London W1T 3JH, UK



## Organic Preparations and Procedures International

Publication details, including instructions for authors and subscription information:

<http://www.informaworld.com/smpp/title~content=t902189982>

### RECENT PROGRESS IN THE CHEMISTRY OF ACYLSILANES. A REVIEW

Pier F. Cirillo<sup>a</sup>; James S. Panek<sup>a</sup>

<sup>a</sup> Department of Chemistry, Metcalf Center for Science and Engineering, Boston University, Boston, MA

**To cite this Article** Cirillo, Pier F. and Panek, James S.(1992) 'RECENT PROGRESS IN THE CHEMISTRY OF ACYLSILANES. A REVIEW', *Organic Preparations and Procedures International*, 24: 5, 553 – 582

**To link to this Article:** DOI: 10.1080/00304949209356728

**URL:** <http://dx.doi.org/10.1080/00304949209356728>

PLEASE SCROLL DOWN FOR ARTICLE

Full terms and conditions of use: <http://www.informaworld.com/terms-and-conditions-of-access.pdf>

This article may be used for research, teaching and private study purposes. Any substantial or systematic reproduction, re-distribution, re-selling, loan or sub-licensing, systematic supply or distribution in any form to anyone is expressly forbidden.

The publisher does not give any warranty express or implied or make any representation that the contents will be complete or accurate or up to date. The accuracy of any instructions, formulae and drug doses should be independently verified with primary sources. The publisher shall not be liable for any loss, actions, claims, proceedings, demand or costs or damages whatsoever or howsoever caused arising directly or indirectly in connection with or arising out of the use of this material.

**RECENT PROGRESS IN THE CHEMISTRY OF ACYLSILANES. A REVIEW**

Pier F. Cirillo and James S. Panek\*

*Department of Chemistry  
Metcalf Center for Science and Engineering  
Boston University, Boston, MA 02215*

INTRODUCTION .....	555
I. STRUCTURE AND REACTIVITY OF ACYLSILANES .....	555
1. Inductive Effects.....	555
2. Field Effects.....	556
3. (p-d) $\pi$ Bonding .....	556
4. Hyperconjugation.....	556
II. SYNTHESIS OF ACYLSILANES .....	568
III. REACTIONS OF ACYLSILANES .....	562
1. Conversion to Aldehydes and Generation of Acyl Anions.....	562
2. Acylsilanes as Radicalphiles in Intramolecular Cyclizations .....	567
IV. STEREOSELECTIVE TRANSFORMATIONS OF ACYLSILANES .....	568
1. Stereoselective Nucleophilic Additions.....	568
2. Additions to $\alpha,\beta$ -Unsaturated Acylsilanes .....	569
3. Additions to $\alpha$ -Substituted Acylsilanes .....	571
4. Diastereoselective Aldol Condensations .....	575
5. Asymmetric Reductions of Acylsilanes. Preparation of $\alpha$ -Hydroxysilanes.....	576
V. REFERENCES.....	579

## RECENT PROGRESS IN THE CHEMISTRY OF ACYLSILANES. A REVIEW

Pier F. Cirillo and James S. Panek\*

*Department of Chemistry  
Metcalf Center for Science and Engineering  
Boston University, Boston, MA 02215*

## INTRODUCTION

It has been nearly twenty-five years since the first acylsilane was isolated and characterized. Since then, our knowledge concerning the preparation and synthetic utility of acylsilanes has steadily increased resulting in the emergence of a class of versatile organosilane reagents. This is due to the ease with which the acylsilane functional group can be introduced in organic molecules, and the wide range of stereoselective bond-forming processes that they participate in. Many of these transformations allow the preparation of complex organic molecules that are silicon-free. Acylsilanes have been used as aldehyde equivalents in stereoselective nucleophilic addition reactions and related  $\alpha,\beta$ -unsaturated acylsilane derivatives have been shown to function as Michael acceptors in conjugate addition reactions. Most recently there has been impressive development in the area of asymmetric reductions by chiral catalysts providing a viable route to enantioenriched  $\alpha$ -alkoxy silanes.

Two reviews concerning the physical characteristics, synthesis and chemistry of acylsilanes have been published in 1989<sup>1</sup> and 1990.<sup>2</sup> The present review article covers the recent developments of acylsilane chemistry over the last two and one-half years with emphasis on diastereoselective addition reactions. Additionally, further transformations of the compounds derived by addition to an acylsilane, to silicon-free molecules will also be discussed. The review is divided into five sections; including structure and reactivity of acylsilanes, new syntheses of acylsilanes, reactions of acylsilanes and stereoselective transformations of acylsilanes.

## I. STRUCTURE AND REACTIVITY OF ACYLSILANES

Earlier published reviews concerning the structure of acylsilanes have primarily focused on their spectroscopic properties.<sup>2</sup> The versatility of acylsilanes in stereoselective bond forming reactions can be attributed to the directing effect imparted by the silicon group and the ease with which it can be removed from the organic molecule. The fact that silicon can function as an electron donor and acceptor clearly enhances its utility. The reactivity and selectivity of reactions involving acylsilanes is dependent upon the steric components and associated electronic effects. The electronic components of silicon can be placed into four categories: [i] inductive effects, [ii] field effects, [iii] p-d  $\pi$  bonding and [iv] hyperconjugative effects. However, the factors which influence selectivity in reactions involving acylsilanes are not solely a result of electronic contributions but rather a combination of variables including steric components. A brief summary of the physical properties of organosilanes is helpful.

## 1. Inductive Effects

Inductive effects are generally considered to be transmitted through the  $\sigma$ -framework of a

molecule, and the electronegativity of an element is usually a measure of its ability to attract  $\sigma$ -electrons.<sup>3a,b</sup> In many synthetic operations selectivity is a reflection of the energy differences between reagents, activated intermediates and transition states. Thus, caution must be exercised when considering the influence of electronic effects on selectivities of reactions involving organosilanes. Through purely inductive effects, trialkyl silicon groups are electron donating; the inductive effects of silicon are weak and they generally have an influence only on atoms directly bonded to it. In this regard, electron donation by the trialkylsilane towards the carbonyl group will further polarize the C=O  $\pi$  system resulting in a decrease in C-Si bond strength.

## 2. Field Effects

Fields effects describe the polarization of an adjacent  $\pi$ -system to the s-dipole moment of the entire  $R_3Si$  group.<sup>2,3</sup> A  $\pi$ -inductive effect, is one that alters a nearby  $\pi$ -system without charge transfer to or from that system. Two types of  $\pi$ -inductive effects have been described.<sup>4</sup> The first is termed  $\pi_\sigma$  and is a result of charge differences in the  $\sigma$ -bonding system, as a consequence of inductive effects. The second  $\pi$  inductive effect  $\pi_\phi$  is the field effect, and arises when the electric dipole of the  $(CH_2)_n Y$  affects the entire  $\pi$ -system through polarization. Both  $\pi_\sigma$  and  $\pi_\phi$  contribute to the overall  $\pi$ -electron density, but it is difficult to separate these effects when they can operate mainly at the  $\alpha$  position. For trialkylsilyl groups it is not easy to predict what the magnitude of the field effect may be, because although the Si-C bond is polarized such that silicon bears partial positive charge, the trialkylsilicon group can also be electron withdrawing, depending on the R-substituents on silicon.

## 3. (p-d) $\pi$ Bonding

The mechanism by which trialkylsilicon group can function as a  $\pi$ -electron withdrawing group is brought about by its physical properties. The most widely recognized explanation is that the low-lying, unoccupied silicon d-orbitals can participate in (p-d)  $\pi$ -bonding as illustrated with Fig. 1.<sup>3,4</sup> In this illustration the electron density from the p-orbital on X can be delocalized onto silicon through a donor - acceptor interaction with the vacant Si 3d orbital. Pauling was the first to introduce this concept to provide an explanation for the short lengths of silicon-oxygen and silicon-halogen bonds.<sup>5</sup> The (p-d)  $\pi$  bonding model is most easily applied to systems in which electron density in a p-type orbital adjacent to silicon is transferred onto the silicon atom.

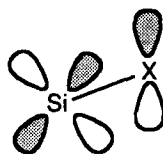

Fig. 1

## 4. Hyperconjugation

When two adjacent molecular orbitals are relatively close in energy and have appropriate symmetry, they can undergo perturbation resulting in the lowering of the energy of one orbital and increasing the other. This phenomenon is illustrated below in Fig. 2 for the interaction of the Si-C  $\sigma^*$

orbital with a p-orbital.<sup>3,5</sup> In this example the  $\pi$ -orbital is lowered in energy through hyperconjugation and this would be reflected in the ionization potential. The magnitude of the hyperconjugative interaction is directly proportional to the energy difference between the orbitals and the orbital coefficients.

The hyperconjugation model when applied to carbocation stabilization in related organosilane systems is illustrated in Fig. 3.

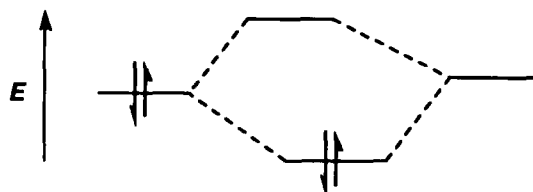

Fig. 2

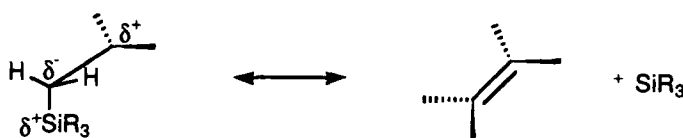

Fig. 3

Collectively, these directing effects are responsible for greatly enhancing the synthetic utility of the acylsilane group. In this regard some well-known principles have emerged. One principle is the ability of silicon to stabilize an adjacent negative charge, by overlap of the carbanion center with a low-energy unoccupied 3d-orbital or by  $\sigma \rightarrow \sigma^*$  orbital overlap. The second concerns the notion that carbocations  $\beta$  to silicon are stabilized by the overlap of the  $\sigma$  orbital of the carbon-silicon  $\sigma$  bond with the vacant p orbital of the adjacent carbocation. The reactivity and ultimately the utility of these reagents is dependent upon on the relative bond strength, relative electronegativity and involvement of the  $3s^2 3p^2 3d^0$  valence configuration in analogy to carbons  $2s^2 2p^2$  configuration and may involve the partially filled valence 3p or vacant 3d atomic orbitals.<sup>6a,b,3a</sup> In addition the participation of high-lying  $\sigma$ - or low lying  $\sigma^*$ -molecular orbitals may influence the overall reactivity of the organosilicon stabilized carbanion. An important aspect controlling the reactivity is the polarization of the carbon-silicon bond resulting from the high electronegativity of the carbon atom relative to silicon. As a result of this polarization addition reactions involving silicon stabilized carbanions show that the emerging carbocation  $\beta$  to silicon is stabilized by the overlap of  $\sigma$  orbital of the carbon-silicon  $\sigma$  bond with the vacant p orbital of the adjacent carbocation. Since the carbon-silicon bonding orbital is higher in energy than the carbon-carbon or a carbon-hydrogen bonding orbitals and also has a very large coefficient on the adjacent carbon atom, through-space, hyperconjugative stabilization by silicon is more influential in stabilizing an electron deficient center than an alkyl or a hydrogen substituent. With regard to acylsilanes, ground state mesomeric effects acting between the silicon d orbitals and the adjacent carbonyl group [ $\pi$  ( $\pi$ -d) bonding] may be expected to give rise to higher carbonyl absorption frequencies. However, large differences in electronegativity between carbon and silicon allow the release of elec-

trons towards the carbonyl group leading to a lowering of the absorption frequency.<sup>2</sup> This trend is consistent with the strong inductive release of electrons from the electropositive silicon.

## II. SYNTHESIS OF ACYLSILANES

The first practical approaches to acylsilanes through the use of cyclic 1,3-dithianes were developed by Brook<sup>7</sup> and Corey<sup>8</sup>, since then many other syntheses have been reported which have been adequately covered in recent reviews.<sup>1,2</sup> Hence, only reaction methodology that has been developed in the last two years will be presented here. In this regard, Yamamoto has reported that the asymmetric Claisen rearrangement of trans-allylic  $\alpha$ -(trimethylsilyl)vinyl ethers **1** promoted by a C<sub>2</sub>-symmetric, organoaluminum reagent (*R*)- or (*S*)-**2** produces optically active acylsilanes **3** in good yields and high optical purity (80-90%).<sup>9</sup> The rearrangement was postulated to involve a chair-like transition state **A**, under the influence of (*R*)-**2**. The chiral aluminum reagent discriminates between the two enantiomeric transition states **A** and **B** only by the difference in orientation of the  $\alpha$ -methylene groups. In this case only one conformation makes a good match for the molecular cleft of the aluminum reagent. The overall transformation is illustrated in Scheme 1 with the (*R*)-**2** stereoisomer.

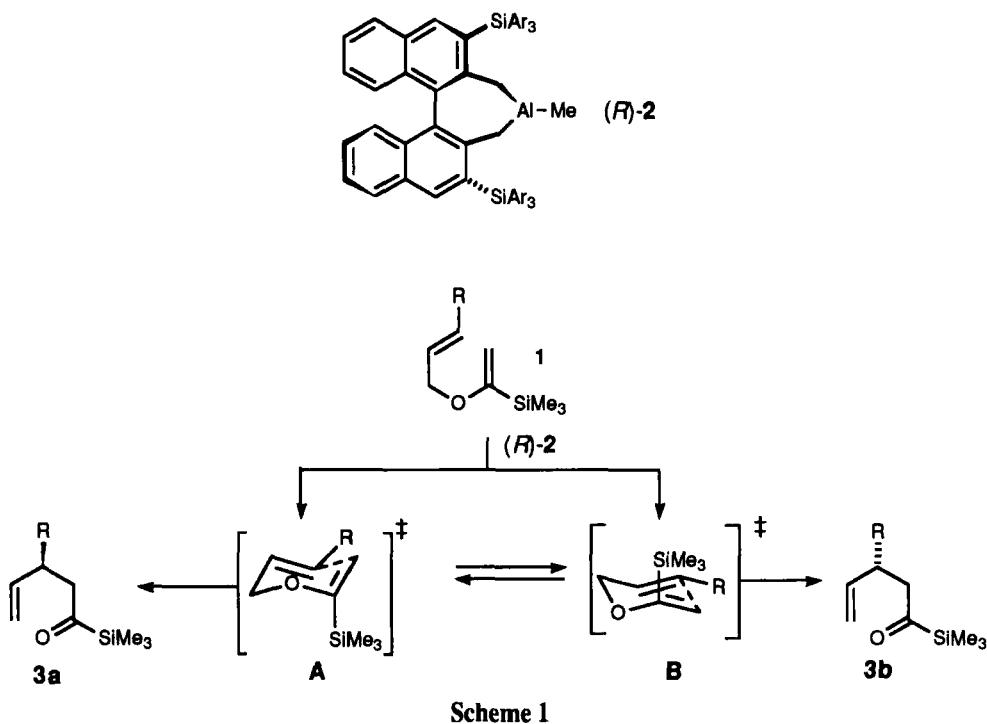

This method, in addition to its asymmetric character, should provide a facile route to the general synthesis of acylsilanes and germanes. An interesting example illustrating the utility of this approach is the enhanced diastereoselection between the thermal promoted reaction and the catalyzed process with ( $\pm$ )-**2** (Scheme 2).<sup>9</sup>

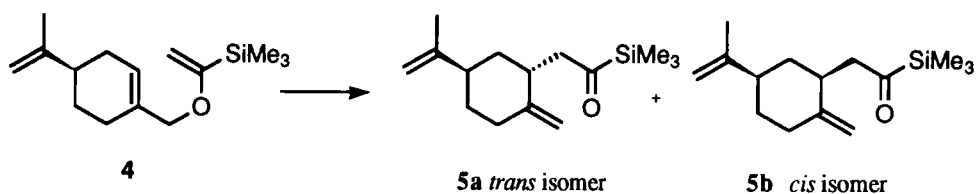

Thermal promoted Claisen at 200 ° C; 85:15, 91%  
 Reaction Conditions:  
 Catalyzed Claisen with (±)-2 at -20 ° C; 97:3, 75%

Scheme 2

The asymmetric Claisen rearrangement of *cis*-allylic  $\alpha$ -(trimethylsilyl)vinyl ethers of structural type **6** promoted by (*R*)-**2** also lead to optically active acylsilanes **3** which possess the same absolute configuration as those from the corresponding *trans*-allylic ethers **1**.<sup>10</sup> The enantiomeric excess for these reactions vary from 50 to 78 % and yields fall in a range from 44 to 81%. The enantioselectivity of the Claisen rearrangements increase with lowering of reaction temperature. This rearrangement has been postulated to occur *via* a boat-like transition state **D** rather than the normal chair-like transition state **C**, in view of the severe 1,3-diaxial interaction between the R substituent and the bulky trimethylsilyl group in **C** (Scheme 3).

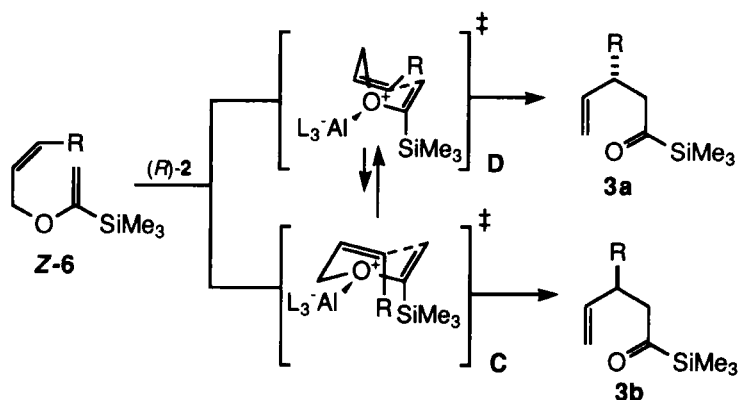

Scheme 3

Yoshida, Isoe and coworkers have developed a one-carbon homologation of aldehydes to generate saturated,  $\alpha,\beta$ -unsaturated and ( $\alpha$ -haloacyl)silanes.<sup>11</sup> The general procedure is summarized in Scheme 4 and is initiated by the lithiation of methoxy bis(trimethylsilyl) methane using *n*-butyllithium (1 equiv, -78°) in THF. The resulting silicon stabilized anion is allowed to react with aldehydes to produce alkene **7** from addition and Peterson-type elimination (no *E:Z* ratio was given). The crude enol ether was hydrolyzed with dilute hydrochloric acid in THF to give the corresponding acylsilane **8**. The yields range from 51 to 92%.

The enol ether intermediates can be isolated and can be allowed to react with electrophiles. For example treatment of **7** with *N*-bromosuccinimide in the presence of a small amount of water in THF affords ( $\alpha$ -bromoacyl)silane **8** in 71% yield (Scheme 5). Similarly, *N*-chlorosuccinimide gave

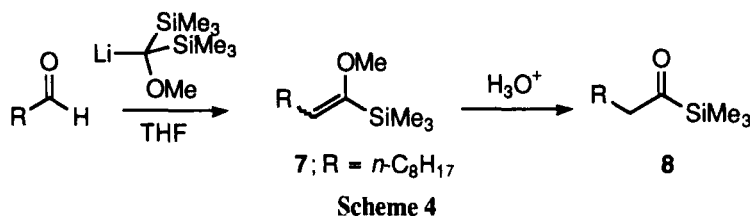

the ( $\alpha$ -chloroacyl)silane in 56 % isolated yield. The reaction of 7 with phenylselenenylchloride on the other hand affords the ( $\alpha$ -phenylselenoacyl)silane in 72% yield as illustrated in Scheme 5. The utility of these transformations is underscored by the fact that this latter compound undergoes a smooth oxidative syn elimination (NaIO<sub>4</sub>, MeOH/H<sub>2</sub>O) to generate  $\alpha,\beta$ -unsaturated acylsilanes.

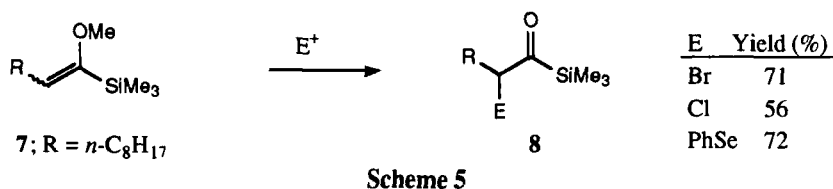

Ohno and coworkers<sup>12</sup> have reported that S-2-pyridyl esters react smoothly with 0.5 equivalents of Al(SiMe<sub>3</sub>)<sub>3</sub> in the presence of CuCN (1.1-1.3 equiv) to afford acylsilanes in excellent yields (Table 1). This method can be applied without any difficulty to  $\alpha$ -substituted, alkoxy and

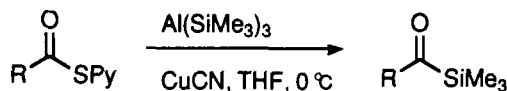

TABLE 1. Synthesis of Acylsilanes from Thioate Esters and Aluminum *tris*(Trimethylsilane)

Entry	S-2-Pyridyl Thioate	Acylsilane	Yield (%) <sup>a</sup>
1			83
2			96
3			98
4			86

(a) Isolated yield after chromatography on SiO<sub>2</sub>.



multifunctionalized compounds.  $\alpha,\beta$ -Unsaturated thioesters undergo instead Michael addition in low yield, producing other products as well.

Recently Suda and coworkers have reported that acylsilanes are easily prepared by the anodic oxidation of 2-alkyl-2-trialkylsilyl-1,3-dithianes using a platinum anode in wet acetonitrile.<sup>13</sup> The results of the anodic oxidation are summarized in Table 2 and illustrate the utility of this method for the preparation of a variety of acylsilanes in good to excellent yields under mild reaction conditions. The electrochemical reaction process provides a general and convenient method to aryl, saturated and  $\alpha,\beta$ -unsaturated acylsilanes.

**TABLE 2.** Synthesis of Acylsilanes *via* Anodic Oxidation of 2-Alkyl-2-trimethylsilyl-1,3-dithianes

Entry	1,3-Dithiane	Acylsilane	Yield (%) <sup>a</sup>
1			95
2			76
3			88
4			96
5			73
6			70
7			84

(a) Isolated yield after chromatography on  $\text{SiO}_2$ .

## III. REACTIONS OF ACYLSILANES

## 1. Conversion to Aldehydes and Generation of Acyl Anions

Acylsilanes are cleaved by dilute alkaline solutions to give aldehydes and other more complex rearrangement products. Benzoyl triphenylsilane dissolved in alcoholic solutions containing a trace of aqueous base rapidly decomposes to triphenylsilanol and benzaldehyde. Three mechanisms that have been proposed are illustrated in Eqs. 1-3. Based on careful kinetic measurements by Ricci, Eq. 2 appears to be the preferred reaction pathway.<sup>14</sup>

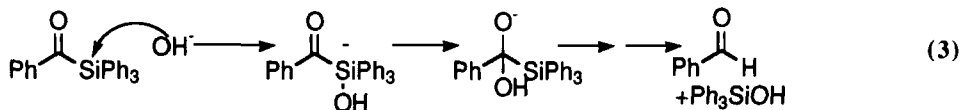
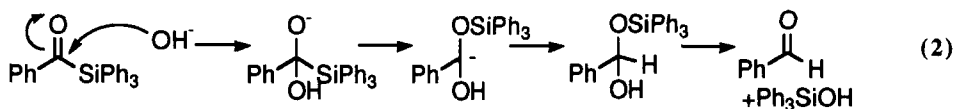
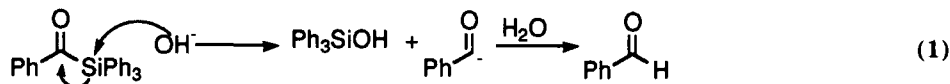

The results can be interpreted by the Brook Rearrangement that involves the 1,2-migration of the triphenylsilane to the oxygen anion,<sup>15</sup> a well documented reaction pathway that follows nucleophilic attack on acylsilanes, the driving force probably being the formation of a strong Si-O bond. It is believed to be the rate-determining step in Eq. 2. By using various optically active acylsilanes, Brook has shown that this rearrangement occurs with retention of configuration at the silicon atom.<sup>16</sup> The stereochemical course of the Brook rearrangement can be accounted for if a pentacovalent trigonal bipyramidal intermediate is involved in the substitution process. Such an intermediate is possible since the empty d-orbitals on silicon are low enough in energy for bonding. The attack of alkoxide ions on acylsilanes follows a very similar pathway (Scheme 6).

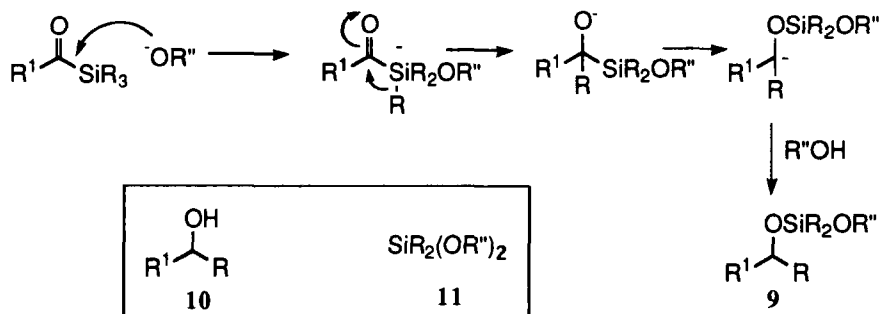

Scheme 6

The major product is usually the unsymmetrical dialkoxysilane 9. Other products, such as alcohol 10 and dialkoxysilane 11, arise from a transesterification reaction between the alkoxide ion and the

unsymmetrical dialkoxysilane. As the polarity of the solvent system increases a competing reaction is observed, involving a nucleophilic displacement of the acyl group from the silicon atom (Scheme 7).

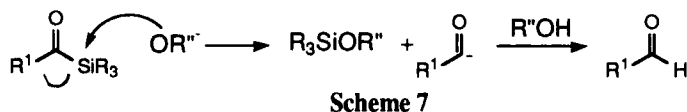

Following this lead, Ricci, Walton and coworkers have studied the potential utility of acylsilanes as acyl anion equivalents (*umpolung* concept).<sup>17</sup> Benzoyltrimethylsilane reacts with a range of alkyl halides at elevated temperatures in the presence of KF and a catalytic amount of 18-crown-6 ether to afford modest yields of product ketone, together with variable amounts of benzil (Table 3).

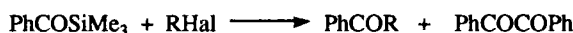

TABLE 3. Ketones Prepared from Acylsilanes and Alkylhalides in the Presence of KF-18-Crown-6<sup>a</sup>

entry	R-Hal	PhCOR (%) <sup>b</sup>	PhCOCOPh (%)	Reaction Conditions <sup>c</sup>
1.	PhCH <sub>2</sub> Br	90	—	A
2.	PhCOCH <sub>2</sub> Br	30	25	B
3.	CH <sub>2</sub> =CHCH <sub>2</sub> Br	25 <sup>d</sup>	30	A, B
4.	MeI	30	20	B

(a) PhCOSiMe<sub>3</sub>-KF-18-crown-6 1:3:0.1. (b) Yield based upon PhCOSiMe<sub>3</sub> consumed. (c) A: 3 hrs, 160°, mesitylene; B: 16 hrs, 80°, THF. (d) ca. 20% of PhC(OH)(COPh)CH<sub>2</sub>CH=CH<sub>2</sub> was also obtained.

Heathcock and Schinzer have reported that benzoyltrimethylsilane can be converted to benzaldehyde in 75% yield by treatment with KF and water in DMSO.<sup>18</sup> This protodesilylation can also be achieved with KF in wet HMPT or with TBAF in wet THF. In the presence of electrophiles, the corresponding alkylated products are formed in modest yields. From a study of substituent effects, Heathcock argues that, for the fluoride-catalyzed process, the mechanism of the desilylation reaction involves direct displacement of the benzoyl anion.

Bulman Page and coworkers<sup>19</sup> have reexamined this procedure and have found that while aryl acyltrimethylsilanes indeed undergo reaction with simple electrophiles in the presence of fluoride ions at all temperatures under neutral or acidic conditions, aryl acylsilanes bearing phenyl groups on the silicon atom and simple alkyl acylsilanes require elevated temperatures and the presence of acid for the cleavage process to occur (for example Eq. 1 in Scheme 8). Furthermore, with the exception of aryl acyltrimethylsilanes, simple acylsilanes in the absence of acid give products arising from alkyl or aryl group migration from silicon to the carbonyl carbon to generate secondary alcohols in good yields (Eq. 2 in Scheme 8 and Table 4).

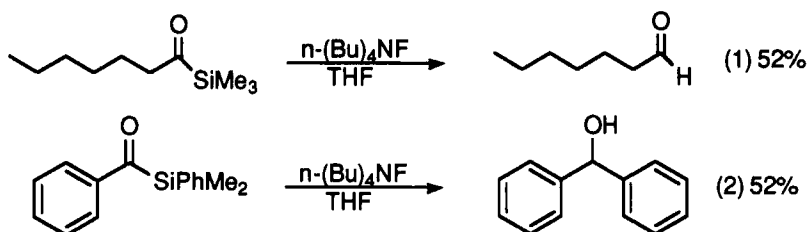
**TABLE 4.** Fluoride Ion Promoted Desilylation of Acylsilanes Involving Alkyl/aryl Migration

Entry	Reaction Conditions <sup>a</sup>	Acylsilane alkyl substituent	SiR <sub>3</sub>	Yield (%) of secondary alcohol
1.	A	CH <sub>3</sub> (CH <sub>2</sub> ) <sub>5</sub>	SiMe <sub>3</sub>	68
2.	A	Ph	SiMe <sub>2</sub> Ph	52
3.	A	Ph	SiPh	54
4.	B	CH <sub>3</sub> (CH <sub>2</sub> ) <sub>5</sub>	SiMe <sub>3</sub>	57
5.	C	CH <sub>3</sub> (CH <sub>2</sub> ) <sub>5</sub>	SiMe <sub>3</sub>	67

(a) A = TBAF (3 equiv.), THF, 25°, 12 hrs; B = TBAF (3 equiv.), THF/H<sub>2</sub>O, 60°, 12 hrs; C = TBAF (3 equiv.), THF/H<sub>2</sub>O, -10°, 12 hrs.

The first step in these reactions is believed to be nucleophilic attack by fluoride ion at the silicon atom to generate a pentacoordinate silicon anionic intermediate. This is followed by either a cleavage to generate the acyl anion and reaction with an electrophile present (similarly to attack by alkoxide, Scheme 7 above), or the migration of an alkyl group from silicon to carbon to produce an alkoxide, Brook rearrangement and fluoride-induced desilylation, thus yielding the rearranged alcohol (Scheme 9).

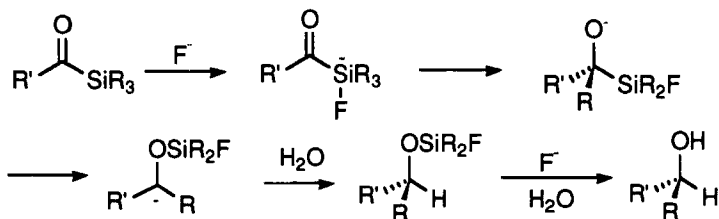

DePuy, Damrauer and coworkers<sup>20</sup> have recently reported the generation in a flowing after-glow apparatus of acetyl anions *via* the reaction shown in Scheme 9. The acyl anion was detected by mass spectrometry and some of its reactions in the gas phase were studied. Pentacoordinate silicon species have also been detected in the gas phase.

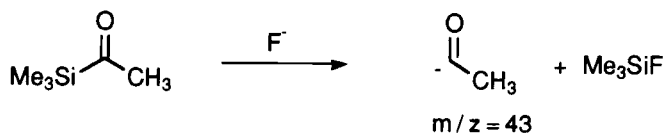

Ricci, Degl'Innocenti and coworkers have reported a synthesis of heteroacylsilanes (compounds **12a-c**) via palladium(II)-catalyzed coupling of hetero-acid chlorides and hexamethyl disilane (Scheme 10).<sup>21</sup>

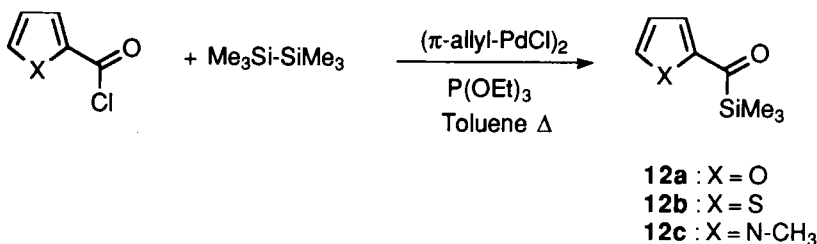

Scheme 10

The reactivity of this class of compounds as nucleophilic acylation agents via fluoride catalysis was then investigated. Satisfactory yields were obtained for the furoyl and thenoyltrimethylsilane (see Table 5) while pyrrolyltrimethylsilane was largely recovered unreacted. This latter's lack of reactivity is more likely due to steric rather than electronic effects.

TABLE 5. Reactions of Heteroacylsilanes **12a-c** with Electrophiles

Entry	Compound <sup>a</sup>	Electrophile <sup>b</sup>	Catalyst/Conditions <sup>c</sup>	Product	Yield (%)
1.	<b>12a</b>	PhCH	CsF/ RT, 6 hrs		68 <sup>f</sup>
2.	<b>12b</b>	PhCHO	CsF / RT, 6 hrs		60
3.	<b>12a</b>	CH <sub>3</sub> (CH <sub>2</sub> ) <sub>2</sub> CHO	CsF/ RT, 3 hrs <sup>d</sup>		55
4.	<b>12b</b>	2-cyclohexenone	CsF/ reflux, 10 hrs		60
5.	<b>12b</b>	PhCH <sub>2</sub> Br	18-crown-6, KF, RT, 10 hrs	PhCH <sub>2</sub> COHet	50

(a) 1:1 Molar ratio of reagents;. (b) 10% Molar with respect to the reagents. (c) Unless otherwise specified run in dry THF. (d) Reaction run in DMF as solvent. (e) Determined by quantitative GC/MS analysis. (f) Isolated yield from column chromatography on SiO<sub>2</sub>.

Kuwajima has reported the conversion of  $\beta$ -alkoxyacylsilanes **15** to  $\alpha,\beta$ -unsaturated aldehydes **16** under the influence of catalytic amounts of quaternary ammonium hydroxide or substituted phenoxides.<sup>22</sup> The  $\beta$ -alkoxyacylsilanes are prepared from  $\text{BF}_3 \cdot \text{OEt}_2$  catalyzed coupling of acetals **14** with silyl enol ethers **13**. Both reactions occur in high yield and the aldehydes produced are usually obtained as the (*E*)-olefins exclusively. With TBAF the reaction proceeds much more slowly and clean conversion cannot be achieved because side product **17**, resulting from methyl transfer from silicon to carbon, is often formed in substantial amount (Scheme 11).

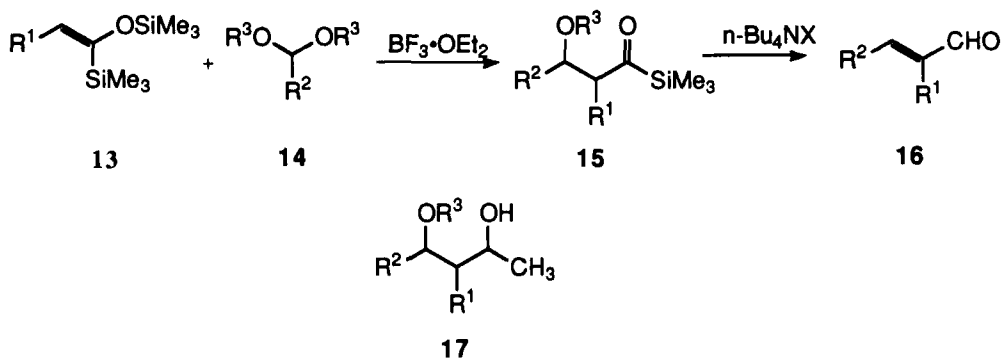

Panek and Cirillo have found that acyldimethylphenylsilanes can undergo mild palladium-catalyzed hydrogenolysis to aldehydes.<sup>23</sup> The Si-carbonyl bond cleavage is quite selective, occurs in high yield and can be performed on  $\alpha$ -alkoxy,  $\alpha,\beta$ -dialkoxo and  $\alpha,\beta,\gamma$ -trialkoxo acylsilanes without the competing elimination pathway. Furthermore the reduction can be carried out in the presence of protecting groups known to be labile to catalytic hydrogenolysis (benzyl and BOM ethers) and acid-sensitive protecting groups (acetonides, TBDMS and MOM ethers) as illustrated with six examples in Table 6.

The lability of acyldimethylphenylsilanes towards hydrogenolysis has been attributed to the abnormal length of the Si-carbonyl bond ( $\sim 0.1$  Å longer than usual C-Si bond), which implies poor orbital overlap. This arises from the electronic structure of acylsilanes, which has been represented by the three resonance forms **18**, **19** and **20**.<sup>24</sup> Interestingly, the corresponding acyltrimethylsilane **21** failed to undergo hydrogenolysis under the same reaction conditions. It is important to note that the acylsilane substrates must be free from any traces of sulfurous compounds that may arise during their formation *via* Swern oxidation, as these contaminants destroy the activity of the palladium on carbon catalyst.

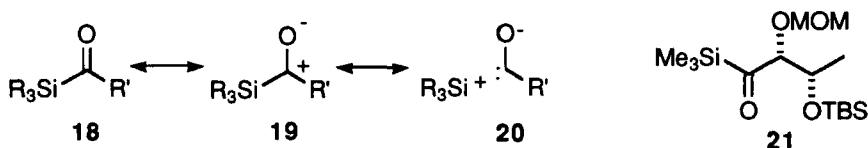

TABLE 6. Palladium Catalyzed Hydrogenations of Acylsilanes

Entry	Acylsilane <sup>a</sup>	Rxn. Time	Aldehyde Product	Yield (%)
1		10 hrs		80
2		24 hrs		82
3		10 hrs		75
4		10 hrs		96
5		12 hrs		82

(a) The hydrogenolysis reactions were run in ethanol, 0.1 M in substrate, at rt, 1 atm. H<sub>2</sub>, and 20% by weight of Pd on activated carbon (Aldrich). (b) All products exhibited the expected <sup>1</sup>H NMR (400 Mhz), <sup>13</sup>C NMR (67.5 MHz), IR, MS and HRMS characteristics. (c) All yields are based on pure materials isolated by chromatography on SiO<sub>2</sub>, and are not optimized.

## 2. Acylsilanes as Radicalphiles in Intramolecular Cyclizations

Recently Tsai and Cherng have demonstrated the utility of acylsilanes in intramolecular radical additions to the carbonyl carbon (Scheme 12).<sup>25</sup> The alkoxy radical that is generated during the

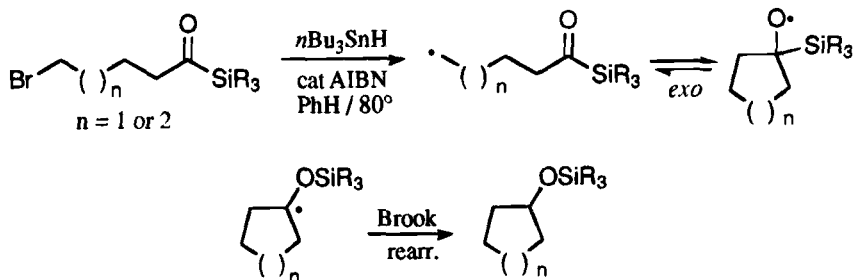

Scheme 12

addition is possibly stabilized by the silicon atom  $\beta$  to it and/or irreversibly trapped as soon as it is formed *via* a radical Brook rearrangement. Silylated cyclopentanol and cyclohexanol that arise from

an *exo* mode of cyclization are obtained in high yields from bromo acylsilanes. Alterations in the steric bulkiness of the silyl group did not affect the cyclization reactions significantly.

#### IV. STEREoseLECTIVE TRANSFORMATIONS INVOLVING ACYLSILANES

##### 1. Stereoselective Nucleophilic Additions

Acylsilanes are sensitive to light and to basic media. However they can behave as the electrophilic partners towards a wide variety of carbanions, thus acting as sterically hindered aldehydes. Wilson and coworkers have used this property of acylsilanes to effect regioselective alkylation of the lithium pentadienyl anion.<sup>26</sup> Thus in the reaction of **22** with acylsilanes **23a** and **23b** only the conjugated dienes **24a** and **24b** are formed, whereas the corresponding aldehydes would provide mixtures of compounds **24** and **25**.

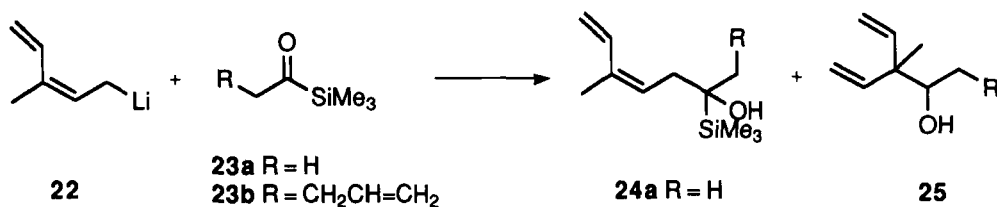

Scheme 13

The trimethylsilyl group, having served its purpose, can be removed *via* a Brook rearrangement, by treatment of the  $\alpha$ -hydroxysilane with KH in HMPA. Compound **24b** undergoes a highly diastereoselective Diels-Alder reaction (Scheme 14) if desilylation is delayed until after the reaction. In this case only one isomer of the two possible diastereomers was formed **26**, arising presumably from the transition state having the bulky silicon moiety in a pseudoequatorial orientation. Thus acylsilanes, acting as sterically hindered aldehydes, in this case offer two major advantages over the use of simple aldehydes: [i] they are less prone to self condensation, thus affording greater yields; [ii] the bulky trimethylsilyl group can be used to control the stereochemistry of the subsequent reactions.

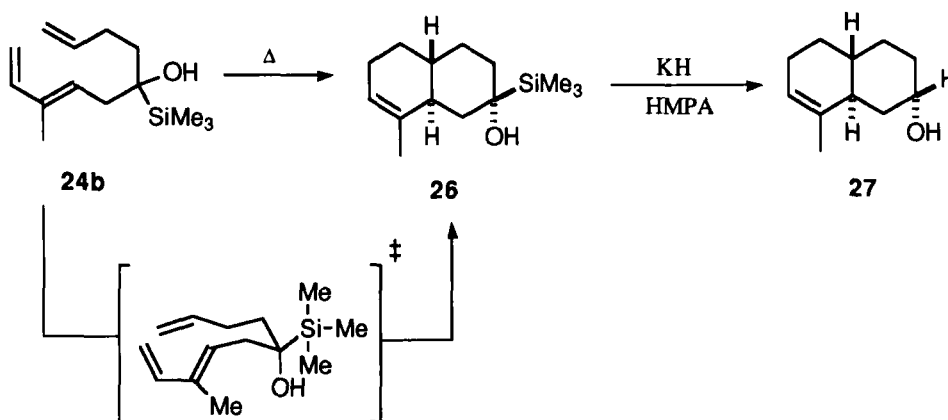

Scheme 14



Miller and Zweifel have developed a convenient synthesis of acylsilanes *via* the monohydroboration of 1-alkynyl silanes with borane-methylsulfide complex followed by oxidation with anhydrous trimethylamine oxide.<sup>27</sup> This procedure, when applied to bis(trimethylsilyl)-acetylene affords (trimethylsilylacetyl)trimethylsilane **28** which can be elaborated into trisubstituted olefins of defined (*E*)-stereochemistry *via* sequential deprotonation-alkylation-deprotonation-aldolization reactions (Scheme 15).

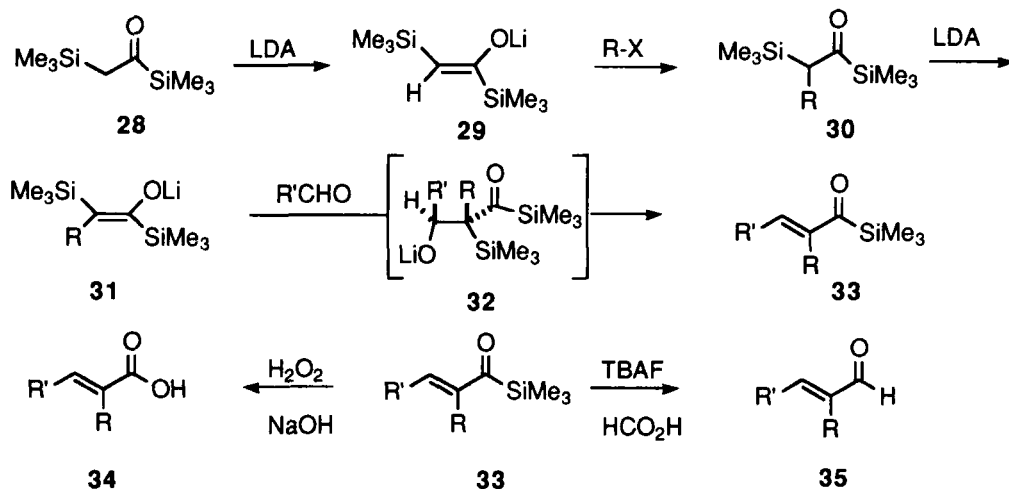

Scheme 15

Since the condensation of lithium enolates and aldehydes are subject to kinetic stereoselection, the reaction of enolate **31** with an aldehyde must produce the intermediate  $\beta$ -alkoxy silane anion **32** enroute to the unsaturated acylsilane **33**. Interestingly, the enolates derived from deprotonation of (trimethylsilyl)acetic acid and its esters react with aldehydes to produce mixtures of the corresponding monosubstituted  $\alpha,\beta$ -unsaturated acids and esters. This indicates non-stereoselective formation of the corresponding enolates.<sup>27a</sup> The versatility of the  $\alpha,\beta$ -unsaturated acylsilanes is demonstrated by the conversion to  $\alpha,\beta$ -unsaturated acid **34** with alkaline hydrogen peroxide and to the corresponding aldehyde **35** by fluoride ion induced protodesilylation.

## 2. Additions to $\alpha,\beta$ -Unsaturated Acylsilanes

$\alpha,\beta$ -Unsaturated acylsilanes serve as highly reactive carboxylic acid equivalents in conjugate addition reactions with allyl and allenylsilanes.<sup>28</sup> These transformations have recently been reviewed by Panek.<sup>6m</sup> The trimethylsilyl acylsilanes provide the basis for a [3+3] annulation approach to six-membered carbocycles. By manipulating the trialkylsilyl group of the acylsilane the course of the annulation reaction can be controlled to produce either five- or six-membered rings. The  $\alpha,\beta$ -unsaturated acylsilanes combine with allenylsilanes at  $-78^\circ$  in the presence of  $\text{TiCl}_4$  to produce the trimethylsilyl-cyclopentene annulation products in good yield. The noteworthy feature of these annulations is that they proceed significantly faster than the analogous reactions using  $\alpha,\beta$ -unsaturated ketones. Furthermore  $\alpha,\beta$ -unsaturated carboxylic acids and esters are generally unreactive in conju-

gate allylation reactions with allylsilane derivatives (Scheme 16).

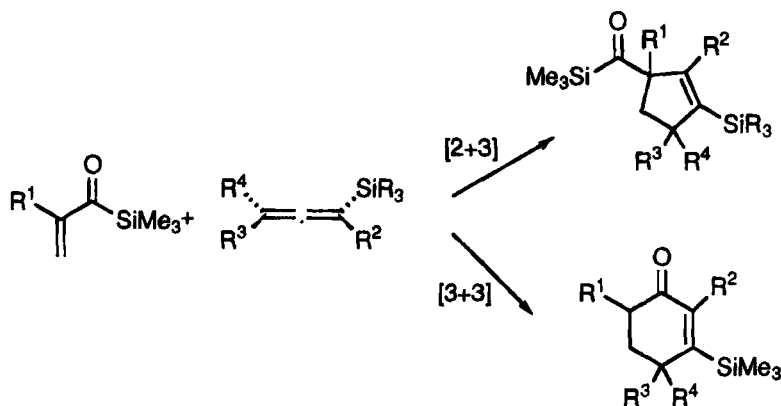

Scheme 16

The annulation products derived from 2-alkylsubstituted  $\alpha,\beta$ -unsaturated acylsilanes undergo a rearrangement to  $\beta$ -silylcyclohexanone derivatives when treated with  $\text{TiCl}_4$ . The annulation process commences with the regiospecific electrophilic substitution at the C3-position of the allenylsilane producing a vinyl carbocation which undergoes a 1,2-cationic trimethylsilyl shift to yield an isomeric vinyl carbocation. Cyclization then gives the [3+2] annulation product. Ring expansion of the cyclopentene next generates the tertiary carbocation which undergoes a second 1,2-anionic trimethylsilyl shift to produce the cyclohexanone.<sup>60,28</sup>

Acetylenic silyl ketones have not been extensively studied. Very recently Degl'Innocenti, Ricci and coworkers have reported that acetylenic triphenylsilyl ketones undergo smooth Michael additions with different silylated nucleophiles to afford  $\beta$ -functionalized propenoylsilanes (Table 7 and Scheme 17).<sup>29</sup> These additions appear to be regiospecific, no trace of the 1,2 adduct being detected in the crude reaction mixture; and stereospecific, giving rise to only one double bond isomer depending on the type of nucleophile used (Table 7).

TABLE 7. Reactivity of Acetylenic Silyl Ketones with Nucleophiles.<sup>a</sup>

Entry	Nucleophile	Product	Yield(%) <sup>b</sup>	Entry	Nucleophile	Product	Yield(%) <sup>b</sup>
1	$\text{Et}_2\text{N-SiMe}_3$		73	3	$\text{H}_2\text{N-SiPh}_3$		57 <sup>c</sup>
2	$\text{PhS-SiMe}_3$		59	4	$\text{I-SiMe}_3$		67

(a) Reactions were run in chloroform at r.t. for 1 hr. (b) Yields refer to chromatographically pure material. (c) 1 hr 60°.

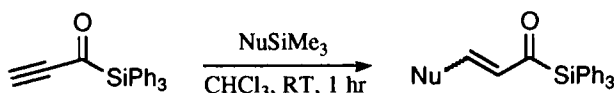

Scheme 17

### 3. Additions to $\alpha$ -Substituted Acylsilanes

Among the many important aspects surrounding the utility of acylsilanes is their ability to function as aldehyde equivalents in stereoselective nucleophilic addition reactions. Ohno and coworkers have recently demonstrated that enhanced levels of 1,2 asymmetric induction in the Cram sense can be achieved in non-chelation controlled addition reactions on ( $\alpha$ -alkylacyl)silanes (Scheme 18).<sup>30</sup> According to the important observation and explanation of Cherest, Felkin and Prudent, asymmetric induction increases in the series of compounds **36** as the size of R increases producing the Cram-type products **37**.<sup>31</sup>

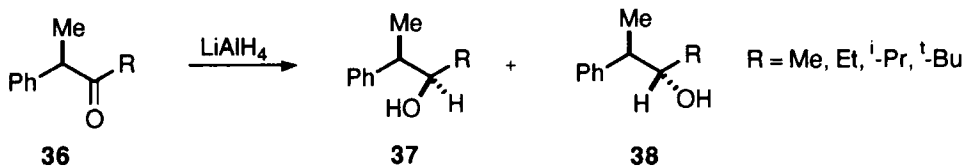

Scheme 18

$\alpha$ -Substituted acylsilanes are ideal chiral carbonyl compounds because: (a) the silicon group is bulky enough to cause strong stereodifferentiation between transition states **39A** and **39B**, (b) the silyl moiety can be stereospecifically replaced by hydrogen after nucleophilic addition and (c) the acylsilanes are stable and easy to handle.

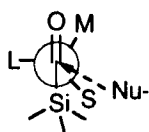
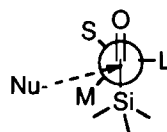
**39A** (preferred conformer)**39B** (disfavored conformer)

Summarized in Table 8 are the results of reactions of organolithium and Grignard reagents with acylsilanes. The reactions afford  $\alpha$ -hydroxysilanes with levels of diastereoselection reaching to >100:1, in good yields. These can be protodesilylated with >99% retention of configuration in moderate to good yields (39-89%) to afford syn products with remarkably high selectivity that are not ordinarily accessible through nucleophilic additions to chiral aldehydes. The best results are achieved when the chiral center is substituted with a phenyl group.

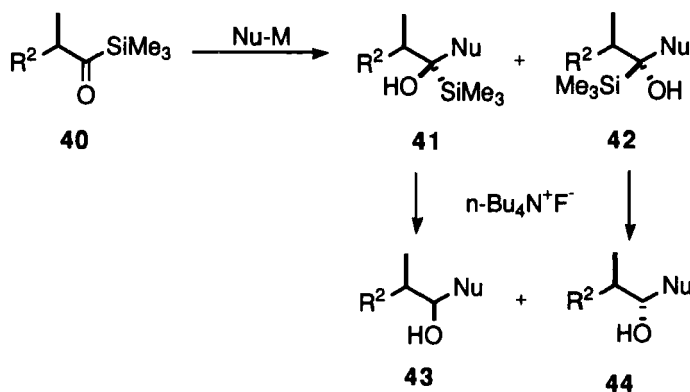

Scheme 19

TABLE 8. Diastereoselectivity in Reactions of Nucleophiles with  $\alpha$ -Substituted Acylsilanes

Entry	R <sup>2</sup>	Nu-M <sup>a</sup>	Yield (%) <sup>b</sup> [41 + 42]	$\alpha$ -Hydroxysilane <sup>c</sup> ratio [41 : 42]	Yield [43 + 44]	Protodesilylation <sup>e</sup> ratio [43 : 44]
1	Ph	n-BuLi	92	>100:1	89	>100:1
2	Ph	MeLi	96	>40:1	76	>40:1
3	Ph	Allyl-TMS, TiCl <sub>4</sub>	68	>100:1	56	>40:1
4	Ph	BrMgCH=CH <sub>2</sub>	96	11:1	85	11:1
5	1-cyclohexyl	Allyl-TMS, TiCl <sub>4</sub>	96	>100:1	79	>100:1

(a) 2.0 Equiv of the nucleophiles were used. (b) Isolated yield after chromatography on SiO<sub>2</sub>. (c) Determined by <sup>1</sup>H-NMR (400 MHz). (d) Isolated yield from starting R<sup>2</sup>. (e) Determined by <sup>1</sup>H-NMR (400 MHz) or GLC analysis.

In a related study, Cirillo and Panek have shown that ( $\alpha,\beta$ -dialkoxyacyl)silanes undergo chelation-controlled addition reactions with a variety of carbon nucleophiles to generate all-syn triols.<sup>32</sup> The acylsilanes were generated by a diastereoselective osmium tetroxide-catalyzed dihydroxylation on chiral C1-oxygenated allylic silanes, followed by highly selective and high yielding protection and deprotection steps and finally Swern oxidation (Scheme 20).

Representative examples of the diastereoselective addition to syn- $\alpha$ -alkoxy-( $\beta$ -silyloxy)acylsilanes **47** are shown in Table 9. Allylation using allylmagnesium bromide showed little diastereoselectivity; however vinyl and phenyl Grignard reagents showed selectivities up to >98:2. The best system for allylation involved the use of tributylallyltin and zinc chloride. The resulting levels of 1,2-asymmetric induction are comparable to those obtained from the corresponding aldehydes. The bulky trialkylsilicon group on the oxygen at the C3 position, together with the ether protecting group on the C2 oxygen, facilitate the formation of transition state **49A**, leading to the production of the syn product. The formation of the alternative transition state **49B**, which leads to the production of the minor

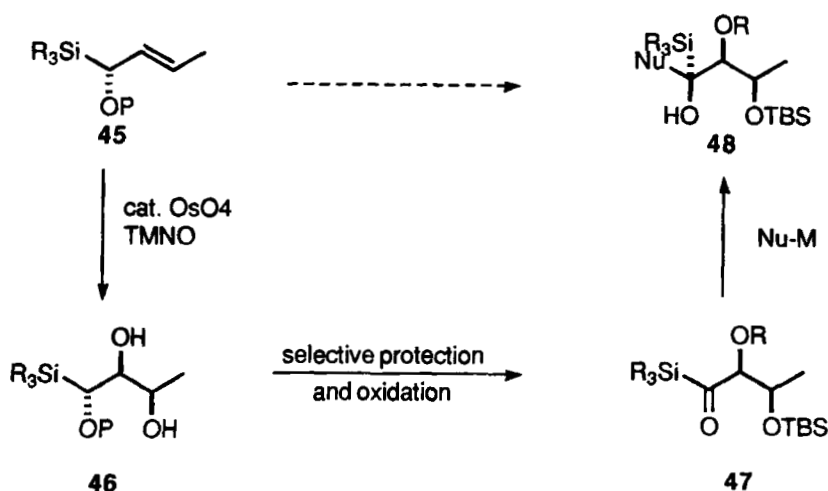

anti diastereomer through 1,3-asymmetric induction, should be minimized resulting from the poor chelating ability of the trialkylsilyl ether (Fig. 4).



T.S. 49A; 1,2-asymmetric induction

T.S. 49B; 1,3-asymmetric induction

Fig. 4

Interestingly, the larger (phenyldimethylacyl)silanes yielded lower levels of *syn*-selectivity than their trimethylsilyl analogues. The products underwent a bisprotodesilylation at both the C3-oxygen and -stereospecifically- at the C1-carbon, in modest yields (up to 58%). This strategy was employed for the synthesis  $\beta$ -D-boivinose, a 2,6-dideoxy monosaccharide antibiotic, from optically-active C1-oxygenated crotylsilane 45.

In an earlier study, Reich and co-workers described a synthesis of regio- and stereoisomerically defined enol silyl ethers from  $\alpha$ -thiophenylacylsilanes and related derivatives.<sup>33</sup> The  $\alpha$ -heteroatom substituted acylsilanes underwent highly diastereoselective nucleophilic addition reactions in the Felkin-Ahn mode (PhS group anti to attacking nucleophile), to give predominantly *erythro* diastereomers. The attacking nucleophiles were non-chelating alkylolithium reagents or aluminum hydride donors. The resulting  $\alpha$ -silyl alkoxides were then allowed to undergo, *in situ*, the stereospecific Brook rearrangement (C  $\rightarrow$  O silyl migration) and the elimination of the phenylthiolate group. It was observed that the major *erythro* diastereomer undergoes this seemingly concerted process at a much faster rate than the *threo* diastereomer. This difference was ascribed to the stereoelectronic

TABLE 9. Diastereoselective Addition Reactions with *syn*- $\alpha$ -Alkoxy- $\beta$ -(silyloxy)acylsilanes

Entry	Acylsilane 47	Nucleophile (Lewis acid) <sup>a</sup>	Major Diastereomer 48	Yield(%) <sup>b</sup> ( <i>syn</i> : <i>anti</i> ratio) <sup>c</sup>
1		Allyl-Sn(Bu) <sub>3</sub> (ZnCl <sub>2</sub> )		96 (91 : 9)
2		Vinyl-MgBr		88 (87 : 13)
3		Allyl-Sn(Bu) <sub>3</sub> (ZnCl <sub>2</sub> )		85 (91 : 9)
4		Allyl-Sn(Bu) <sub>3</sub> (ZnCl <sub>2</sub> )		86 (74 : 26)
5		PhMgBr		86 (98 : 2)

(a) The addition reactions were run in dry CH<sub>2</sub>Cl<sub>2</sub> 0.15-0.2 M in substrate. (b) All products were isolated as *anti*/*syn* diastereomers and ratios were determined by integration of the crude <sup>1</sup>H NMR spectrum at 93.94 kG (400 MHz). (c) All yields are based on pure materials isolated by chromatography on SiO<sub>2</sub>.

demands of such an E2-like transition state. The silyl group must be eclipsed with H during the Brook rearrangement for the major diastereomer and with the more bulky benzyl moiety for the minor, less reactive diastereomer (Scheme 21).

The ability of acylsilanes to act as sterically hindered aldehydes was employed by Bouffard and Salzmann to introduce a 6 $\alpha$ -[(1*R*)-hydroxyethyl] side chain in a carbapenem system.<sup>34</sup> The aldol reaction between the lithium enolate and acetyltrimethylsilane occurs with good to excellent diastereoselectivity according to transition state illustrated in Fig. 5 and the derived silyl carbinol undergoes a stereo and regioselective 1,2-rearrangement to the desired siloxyethyl product. The overall yields are good ranging between 70-80%.

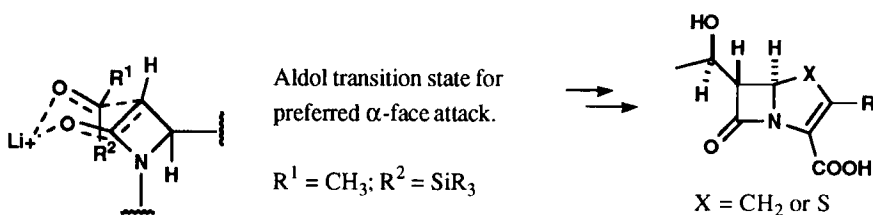
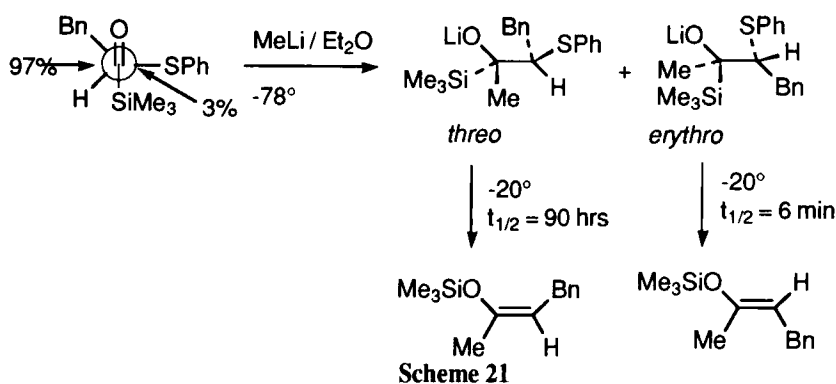

#### 4. Diastereoselective Aldol Reactions

Shinzer has demonstrated that lithium enolates of propanoyl silanes react with modest syn-anti selectivity with aryl and alkyl aldehydes, reaching >20:1 for the latter cases (Scheme 22 and Table 10). Moreover, they show higher levels of diastereoface selectivity with  $\alpha$ -chiral aldehydes than other known achiral lithium enolates.<sup>35</sup>

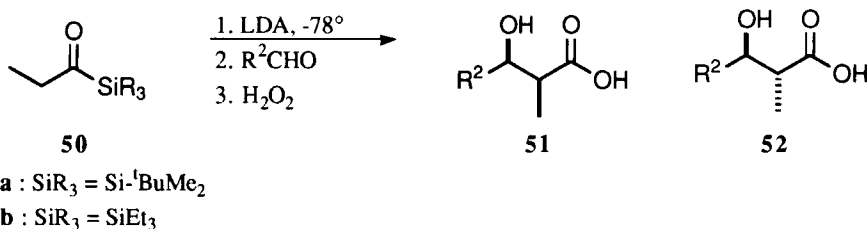
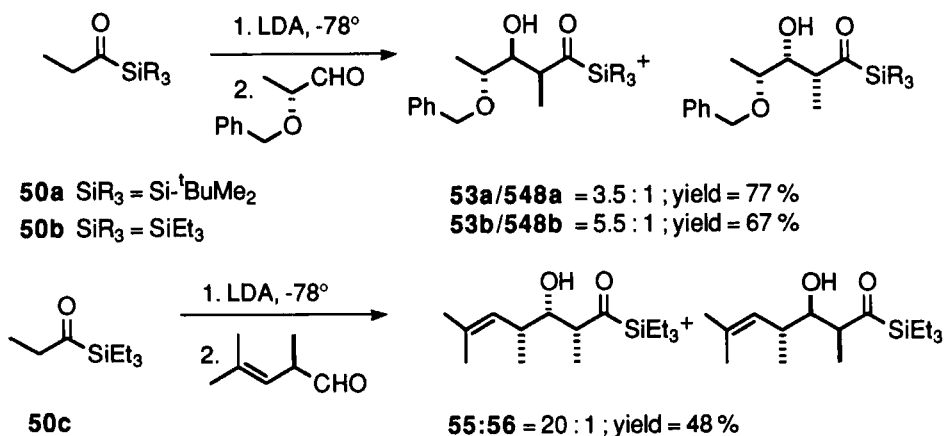

**TABLE 10.** Diastereoselective Aldol Addition of Lithium Enolates Derived from Acylsilanes

Entry	Acylsilane <sup>a</sup>	R <sub>2</sub>	Yield(%) <sup>a</sup>	syn:anti (51 : 52)
1.50a	Ph	68	9 : 1	
2	50a	<sup>i</sup> Pr	31	>20 : 1
3	50a	Ph	48	4 : 1
4	50b	<sup>i</sup> Pr	34	>20 : 1

(a) Relative stereochemistry was determined by comparison of the <sup>1</sup>H-NMR spectra with authentic samples.

Aldol reactions of the derived lithium enolates **50**, with  $\alpha$ -substituted aldehydes are shown in Scheme 23 and afforded the  $\beta$ -hydroxy acylsilanes **47**, **48**, **49** and **50** with modest to good levels of diastereoselection. The corresponding  $\beta$ -hydroxy acids were produced by protodesilylation upon treatment with alkaline hydrogen peroxide.



Scheme 23

Larson, Soderquist and Rivera Claudio have studied the reaction of the lithium enolates of  $\alpha$ -silyl esters with acylsilanes as a potential entry into stereodefined  $\beta$ -silyl- $\alpha,\beta$ -unsaturated esters.<sup>36</sup> In contrast to the high stereoselectivity displayed in the reaction of Wittig reagents with acylsilanes to produce *E*-vinylsilanes, ethyl lithio(trimethylsilyl)acetate reacts with acetyltrimethylsilane **57** to provide the expected ethyl 3-trimethylsilyl-2-butenates **58** and **59** in 50-62% yield as a mixture of *Z* and *E*-stereoisomers (88 : 12 ratio at best; Scheme 24). An increase in the steric bulk of the silyl group of the acylsilane results in an increase in the *Z*-selectivity of the reaction. Increase in the steric bulk of the ester enolate instead decreases the *Z*-selectivity. Systems such as one described above were found to be useful precursors to 3-trimethylsilyl allyl alcohols.

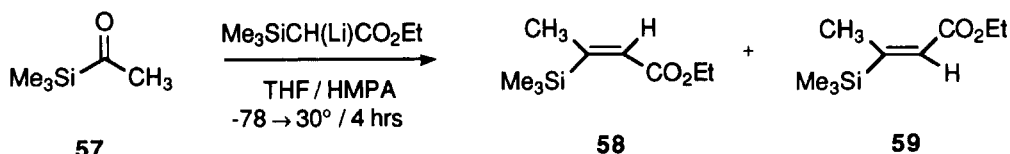

Scheme 24

### 5. Asymmetric Reductions of Acylsilanes. Preparation of Enantioenriched $\alpha$ -Hydroxy-silanes

A number of reports have appeared recently concerning the asymmetric reduction of acylsilanes producing enantioenriched  $\alpha$ -hydroxyacylsilanes **60** (Table 11). In this regard, Buynak and coworkers have investigated the asymmetric reduction of acylsilanes to  $\alpha$ -hydroxysilanes *via* the Itsuno reagent (a 2:1 complex of borane and (*S*)-2-amino-3-methyl-1,1-diphenylbutan-1-ol).<sup>37</sup> Useful



levels of ee's ranging from 50 to 94% were obtained, and not surprisingly, the enantioselectivity of the reaction increased with the steric bulk of the trialkylsilane.<sup>38</sup>

TABLE 11. Asymmetric Reductions of Acylsilanes with the Itsuno Reagent

Entry	Acylsilane <sup>a</sup>	Product <b>60</b>	Yield(%)	ee (%) <sup>a</sup>
1			56	50
2			71	94
3			87	81

(a) Enantiomeric excess was measured by conversion to the Mosher ester and NMR analysis of either the <sup>19</sup>F spectra or <sup>1</sup>H NMR spectra in the presence of Eu(fod)<sub>3</sub> shift reagent.

Acylsilanes have been shown to be useful precursors for the generation of  $\alpha$ -alkoxy silanes by a variety of hydride reducing agents. One of the useful transformations that the derived chiral  $\alpha$ -silyl-carbinols can undergo is a thermal rearrangement of  $\alpha$ -acetoxysilanes to produce the corresponding silyl acetates with migration of one of the alkyl groups from silicon to carbon. Upon treatment with alkaline hydrogen peroxide (Tamao oxidation), these silafunctional compounds are readily and stereospecifically desilylated to the corresponding chiral alcohols with retention of configuration (Scheme 25). The availability of enantiomerically pure  $\alpha$ -alkoxysilanes would certainly broaden the scope and extend the usefulness of this class of compounds.

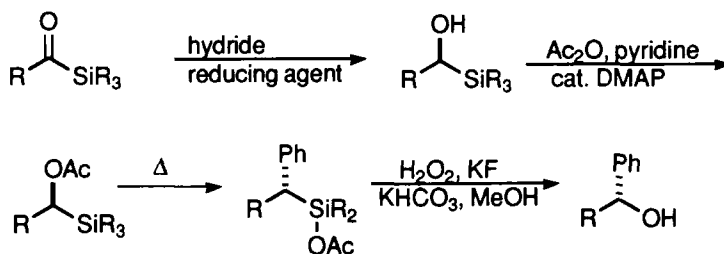

Scheme 25

$\alpha$ -Oxygenated allylic silanes are a closely related class of compounds that have shown promise as useful synthons.<sup>39</sup> The generation of such species in enantiomerically pure form would greatly extend their utility in the context of asymmetric synthesis, and efforts towards this goal have already been performed by Sparks and Panek, *via* the chromatographic resolution of the derived mandelates.<sup>40</sup> This method is however not conveniently applicable for large scale work. Panek and Cirillo have explored the asymmetric reduction of  $\alpha,\beta$ -unsaturated acylsilanes **61**, *via* the CBS catalytic method<sup>41</sup> for the preparation of optically active  $\alpha$ -hydroxy allylic silanes **62**.<sup>42</sup> The results are

summarized in Table 12 and show that only moderate levels of induction were reached.

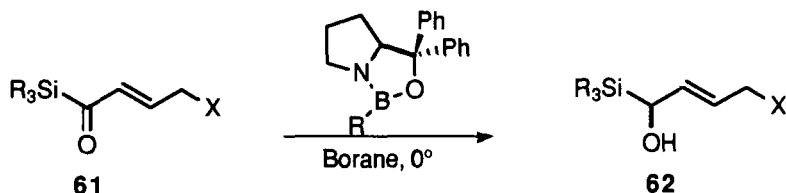

TABLE 12. Catalytic Asymmetric Reductions of  $\alpha,\beta$ -Unsaturated Acylsilanes

Entry	SiR <sub>3</sub>	X	borane (#equiv)	Solvent System	Yield(%) <sup>a</sup>		
					1,2-reduction 62	ee (%) <sup>b</sup>	1,4-reduction
1	PhMe <sub>2</sub> Si	OBn	BH <sub>3</sub> ·THF (0.6)	THF	26	0	51
2	Me <sub>3</sub> Si	H	BH <sub>3</sub> ·SMe <sub>2</sub> (0.6)	CH <sub>2</sub> Cl <sub>2</sub>	35	50	35
3	PhMe <sub>2</sub> Si	H	BH <sub>3</sub> ·SMe <sub>2</sub> (1.2)	CH <sub>2</sub> Cl <sub>2</sub>	41	73	—
4	PhMe <sub>2</sub> Si	OBn	BH <sub>3</sub> ·SMe <sub>2</sub> (1.2)	CH <sub>2</sub> Cl <sub>2</sub>	51	66	21
5	PhMe <sub>2</sub> Si	OBn	CB <sup>c</sup> (1.2)	CH <sub>2</sub> Cl <sub>2</sub> /THF	62	<5 (R)	19

(a) Isolated yield after chromatography on SiO<sub>2</sub>. (b) Enantiomeric excess (ee) and absolute configuration were determined by <sup>1</sup>H-NMR analysis after conversion to (R)-O-acetylmandelate, [cf. B. M. Trost, J. L. Belletire, S. Godleski, P. G. McDougal, J. M. Balkovek, J. J. Baldwin, M. E. Christy, G. S. Ponticello, S. Varga and J. P. Springer, *J. Org. Chem.*, **51**, 2370 (1986)]. (c) catechol borane.

Unfortunately,  $\alpha,\beta$ -unsaturated acylsilanes, as pointed out by Danheiser, are excellent Michael acceptors.<sup>43</sup> Thus significant amounts of the 1,4-reduction could not be entirely suppressed. The use of Noyori's BINAL-H reagent<sup>44</sup> for such reactions has so far also proven to be unsatisfactory, as well as enzymatic reduction with baker's yeast.<sup>41</sup> The resolution of C1-oxygenated allylic silanes has also been attempted *via* the Sharpless method and enzymatically with lipases, both methods without success.<sup>41</sup> This is in sharp contrast with the closely related  $\alpha,\beta$ -unsaturated acylstannanes, which are conveniently reduced with high ee's to C1-oxygenated allylic stannanes by the use of BINAL-H.<sup>45</sup>

Recently, Soderquist<sup>46</sup> and Buynak,<sup>47</sup> and their respective coworkers, have independently shown that acylsilanes can be reduced to the corresponding  $\alpha$ -silyl alcohols *via* the chlorodiisopinocampheylborane system developed by Brown.<sup>48</sup> Generally, addition of the acylsilane to (-)-IPC<sub>2</sub>BCl in THF at room temperature, followed by workup with diethanolamine, provides (R)-alcohols in high enantiomeric excess and in moderate to good yields. Representative examples of the asymmetric chlorodiisopinocampheylborane reduction are given in Table 13.

In conclusion, acylsilanes are readily available, versatile organosilane reagents that are capable of participating in a wide variety of selective bond forming reactions ranging from stereoselective olefinations to highly enantioselective asymmetric reductions. In many cases, after activation and desilylation, the synthesis of silicon-free complex organic molecules with well-defined stereochemistry can be achieved. The continued exploration of these useful functional groups will certainly broaden the scope of their overall synthetic utility.

TABLE 13. Asymmetric Reductions of Acylsilanes (-)-IPC<sub>2</sub>BCl

Entry	Acylsilane <sup>a</sup>	Product	Yield(%) <sup>a</sup>	ee (%)
1			60	98 <sup>c</sup>
2			64	98 <sup>c</sup>
3			56	95 <sup>b</sup>
4			63	96 <sup>b</sup>
5			66	97 <sup>b</sup>
6			11	97 <sup>b</sup>
7			27	83 <sup>b</sup>
8			52	80 <sup>b</sup>

(a) Isolated after column chromatography on SiO<sub>2</sub> gel. (b) Determined by conversion of alcohol to Mosher esters followed by integration of the <sup>19</sup>F-NMR peaks of the diastereomers. (c) Determined by NMR analysis using the chiral solvating agent ((+)-Eu(tfc)<sub>3</sub>).

## REFERENCES

1. A. Ricci and A. Degl'Innocenti, *Synthesis*, 647 (1989).
2. P. C. Bulman Page, S. S. Klair and S. Rosenthal, *Chem. Soc. Rev.*, **19**, 147 (1990).
3. (a) For a review on the activating and directing effects of silicon, see A. R. Bassindale and P. G. Taylor in *The Chemistry of Organic Silicon Compounds part 2*, S. Patai and Z. Rappoport Eds., Wiley, & Sons, New York, NY, pp 893-963 (1989); (b) For a recent theoretical study of the β-effect and leading references, see S. G. Wierschke, J. Chandrasekhar and W. L. J. Jorgensen, *J. Am. Chem. Soc.* **107**, 1496 (1985).
4. C. G. Pitt, *J. Organomet. Chem.*, **61**, 49 (1973).

5. L. Pauling, *The Nature of the Chemical Bond*, 2nd edn., Cornell Press, New York, (1950).
6. For general reviews of organosilicon chemistry, see (a) I. Fleming, *Organic Reactions*, Vol. 37, chap. 2 p. 57 (1989); (b) G. Majetich, *Organic Synthesis: Theory and Application*, Vol. 1 p 173 (1989); (c) H. Sakurai Ed., *Organosilicon and Bioorganosilicon Chemistry: Structure, Bonding, Reactivity, and Synthetic Application*; Halsted, New York, (1985); (d) W.P. Weber, *Silicon Reagents for Organic Synthesis*; Springer-Verlag, Berlin, (1983); (e) E. Colvin, *Silicon in Organic Synthesis*, Butterworths, London, (1983); (f) I. Fleming in *Comprehensive Organic Chemistry*, D. H. R. Barton and W. D. Ollis Eds., Pergamon, Oxford, Vol. 3, p 539 (1979); (g) P. D. Magnus, T. Sarkar and S. Djuric in *Comprehensive Organometallic Chemistry*, G. W. Wilkinson, F. G. A. Stone, F. W. Abel Eds., Pergamon, Oxford, Vol. 7, p 515 (1982); (h) L.A. Paquette, *Science*, **217**, 793 (1982); (i) I. Fleming, *Chem. Soc. Rev.*, **10**, 83 (1981); (j) P. D. Magnus, *Aldrichimica Acta*, **13**, 43 (1980); (k) R. Calas, *J. Organometal. Chem.*, **200**, 11 (1980); (l) T. H. Chan and I. Fleming, *Synthesis*, 761 (1979); (m) E. W. Colvin, *Chem. Soc. Rev.*, **7**, 15 (1978); (n) P. F. Hudrlik in *Journal Organometallic Chemistry Library*, D. Seyferth, Ed., Elsevier, Amsterdam, Vol. 1, p 127 (1976); (o) J. S. Panek in *Comprehensive Organic Synthesis*, B. M. Trost, I. Fleming, S. L. Schreiber Eds., Pergamon, New York, Vol. 1, Ch.2, p 579-627 (1991).
7. A. G. Brook, J. M. Duff, P. F. Jones and N. R. Davis, *J. Am. Chem Soc.*, **89**, 431 (1967).
8. E. J. Corey, D. Seebach and R. Freedman, *ibid.*, **89**, 434 (1967).
9. (a) K. Maruoka, H. Banno and H. Yamamoto, *ibid.*, **112**, 7791 (1990); (b) K. Maruoka, H. Banno, H. Yamamoto, *Tetrahedron: Asymmetry*, **2**, 647 (1991).
10. K. Maruoka and H. Yamamoto, *SYNLETT*, **11**, 793 (1991).
11. J. Yoshida, S. Matsunaga, Y. Ishichi, T. Maekawa and S. Isoe, *J. Org. Chem.*, **56**, 1307 (1991).
12. M. Nakada, S. Nakamura, S. Kobayashi and M. Ohno, *Tetrahedron Lett.* **32**, 4929 (1991).
13. K. Suda, J. Watanabe, and T. Takanami, *ibid.*, **33**, 1355 (1992).
14. D. Pietropaolo, M. Fiorenza, A. Ricci and M. Taddei, *J. Organomet. Chem.*, **197**, 7 (1980).
15. A. G. Brook and A. R. Bassindale in "Rearrangements in Ground and Excited States", P. de Mayo Ed., Academic Press, New York, Vol. 2, 149 (1980).
16. A. G. Brook, *Acc. Chem. Res.*, **7**, 77 (1974).
17. A. Degl'Innocenti, S. Pike, D. R. M. Walton, G. Seconi, A. Ricci and M. Fiorenza, *Chem. Commun.*, 1201 (1980).
18. D. Schinzer and C. H. Heathcock, *Tetrahedron Lett.*, **22**, 1881 (1981).
19. P. C. Bulman Page, S. Rosenthal and R. V. Williams, *ibid.*, **28**, 4455 (1987).

RECENT PROGRESS IN THE CHEMISTRY OF ACYLSILANES. A REVIEW

20. C. H. DePuy, V. M. Bierbaum, R. Damrauer and J. A. Soderquist, *J. Am. Chem. Soc.*, **107**, 3385 (1985).
21. A. Ricci, A. Degl'Innocenti, S. Chimichi, M. Fiorenza, G. Rossini and H. J. Bestmann, *J. Org. Chem.*, **50**, 130 (1985).
22. T. Sato, M. Arai and I. Kuwajima, *J. Am. Chem. Soc.*, **99**, 5827 (1977).
23. P. F. Cirillo and J. S. Panek, *Tetrahedron Lett.*, **32**, 457 (1991).
24. (a) J. Trotter and P. C. Chieh, *J. Chem. Soc. (A)*, 1778 (1969); (b) R. W. Harrison and J. Trotter, *ibid.*, 258 (1966).
25. Y.-M. Tsai and C.-D. Cherng, *Tetrahedron Lett.*, **32**, 3515 (1991).
26. S. R. Wilson, M. S. Hague and R. N. Misra, *J. Org. Chem.*, **47**, 747 (1982).
27. (a) J. A. Miller, and G. Zweifel, *J. Am. Chem. Soc.*, **103**, 6217 (1981); (b) J. A. Miller and G. Zweifel, *Synthesis*, 288 (1981).
28. R. L. Danheiser and D. M. Fink, *Tetrahedron Lett.*, **26**, 2509 (1985).
29. A. Degl'Innocenti, A. Capperucci, G. Reginato, A. Mordini and A. Ricci, *ibid.*, **33**, 1507 (1992).
30. M. Nakada, Y. Urano, S. Kobayashi and M. Ohno, *J. Am. Chem. Soc.*, **110**, 4826 (1988).
31. (a) M. Cherest, H. Felkin and N. Prudent, *Tetrahedron Lett.*, 2199 (1968). (b) N. T. Anh and O. Eisenstein, *Nouv. J. Chim.*, **1**, 61 (1977). (c) A. S. Cieplak, *J. Am. Chem. Soc.*, **103**, 4540 (1981).
32. P. F. Cirillo and J.S. Panek, *J. Org. Chem.*, **55**, 6071 (1990).
33. (a) H. J. Reich, R. C. Holtan and S. L. Borkowsky, *ibid.*, **52**, 312 (1987); (b) H. J. Reich, R.C. Holtan and C. Bolm, *J. Am. Chem. Soc.*, **112**, 5609 (1990).
34. F. A. Bouffard, T. N. Salzmann, *Tetrahedron Lett.*, **26**, 6285 (1985).
35. D. Schinzer, *Synthesis*, 179 (1989).
36. G. L. Larson, J. A. Soderquist and M. Rivera Claudio, *Synth. Commun.*, **20**, 1095 (1990).
37. S. Itsuno, M. Nakano, K. Miyazaki, H. Masuda and K. Ito, *J. Chem. Soc., Perkin Trans. I*, 2039 (1985).
38. J. D. Buynak, J. Byron Strickland, T. Hurd and A. Phan, *Chem. Commun.*, 89 (1989).
39. J. S. Panek and P. F. Cirillo, *J. Am. Chem. Soc.*, **112**, 4873 (1990).
40. J. S. Panek and M. A. Sparks, *Tetrahedron: Asymmetry*, **1**, 801 (1990).

CIRILLO AND PANEK

41. (a) E. J. Corey, R. K. Bakshi, S. Shibata, C.-P. Chen. and V. D. Singh, *J. Am. Chem. Soc.*, **109**, 7925 (1987); (b) E. J. Corey, R. K. Bakshi and S. Shibata, *ibid.*, **109**, 5551 (1987); (c) E. J. Corey, R. K. Bakshi and S. Shibata, *J. Org. Chem.*, **53**, 2861 (1988).
42. P. F. Cirillo and J. S. Panek, Unpublished results.
43. R. L. Danheiser and D. M. Fink, *Tetrahedron Lett.*, **26**, 2513-2516 (1985).
44. (a) R. Noyori, I. Tomino, Y. Tanimoto and M. Nishizawa, *J. Am. Chem. Soc.*, **106**, 6709 (1984); (b) R. Noyori, I. Tomino, M. Yamada and M. Nishizawa, *ibid.*, **106**, 6717 (1984).
45. (a) P. C. M. Chan, and J. M. Chong, *J. Org. Chem.*, **53**, 5584 (1988); (b) J. A. Marshall, G. S. Welmaker and B. W. Gung, *J. Am. Chem. Soc.*, **113**, 647 (1991).
46. J. A. Soderquist, C. L. Anderson, E. I. Miranda and I. Rivera, *Tetrahedron Lett.*, **31**, 4677 (1990)
47. J. D. Buynak, J. B. Strickland, G. W. Lamb, D. Khasnis, S. Modi, D. Williams and H. Zhang, *J. Org. Chem.*, **56**, 7076 (1991).
48. (a) J. Chandrasekharan, P. V. Ramachandran and H. C. Brown, *ibid.*, **50**, 5446 (1985); (b) H. C. Brown, J. Chandrasekharan and P. V. Ramachandran, *ibid.*, **51**, 3394 (1986).

**(Received April 4, 1992; in revised form June 22, 1992)**